

A Story of Ratios[®]

Eureka Math[™]

Grade 8, Module 7

Student File_B

Contains Exit Ticket and Assessment Materials

Published by the non-profit Great Minds.

Copyright © 2015 Great Minds. No part of this work may be reproduced, sold, or commercialized, in whole or in part, without written permission from Great Minds. Non-commercial use is licensed pursuant to a Creative Commons Attribution-NonCommercial-ShareAlike 4.0 license; for more information, go to <http://greatminds.net/maps/math/copyright>. “Great Minds” and “Eureka Math” are registered trademarks of Great Minds.

Printed in the U.S.A.

This book may be purchased from the publisher at eureka-math.org

10 9 8 7 6 5 4 3 2 1

Exit Ticket Packet

Name _____

Date _____

Lesson 1: The Pythagorean Theorem

Exit Ticket

1. Determine the length of the unknown side of the right triangle. If you cannot determine the length exactly, then determine which two integers the length is between and the integer to which it is closest.

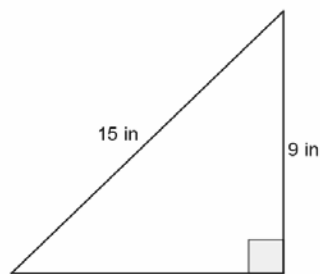

2. Determine the length of the unknown side of the right triangle. If you cannot determine the length exactly, then determine which two integers the length is between and the integer to which it is closest.

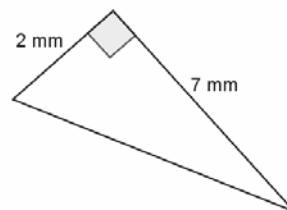

Name _____

Date _____

Lesson 2: Square Roots

Exit Ticket

1. Write the positive square root of a number x in symbolic notation.
2. Determine the positive square root of 196. Explain.
3. The positive square root of 50 is not an integer. Which whole number does the value of $\sqrt{50}$ lie closest to? Explain.
4. Place the following numbers on the number line in approximately the correct positions: $\sqrt{16}$, $\sqrt{9}$, $\sqrt{11}$, and 3.5.



Name _____

Date _____

Lesson 3: Existence and Uniqueness of Square Roots and Cube Roots

Exit Ticket

Find the positive value of x that makes each equation true. Check your solution.

1. $x^2 = 225$

a. Explain the first step in solving this equation.

b. Solve and check your solution.

2. $x^3 = 64$

3. $x^2 = 361^{-1}$

4. $x^3 = 1000^{-1}$

Name _____

Date _____

Lesson 4: Simplifying Square Roots

Exit Ticket

Simplify the square roots as much as possible.

1. $\sqrt{24}$

2. $\sqrt{338}$

3. $\sqrt{196}$

4. $\sqrt{2420}$

Name _____

Date _____

Lesson 5: Solving Equations with Radicals

Exit Ticket

1. Find the positive value of x that makes the equation true, and then verify your solution is correct.

$$x^2 + 4x = 4(x + 16)$$

2. Find the positive value of x that makes the equation true, and then verify your solution is correct.

$$(4x)^3 = 1728$$

Name _____

Date _____

Lesson 6: Finite and Infinite Decimals

Exit Ticket

Convert each fraction to a finite decimal if possible. If the fraction cannot be written as a finite decimal, then state how you know. You may use a calculator, but show your steps for each problem.

1. $\frac{9}{16}$

2. $\frac{8}{125}$

3. $\frac{4}{15}$

4. $\frac{1}{200}$

Name _____

Date _____

Lesson 7: Infinite Decimals

Exit Ticket

1.

a. Write the expanded form of the decimal 0.829 using powers of 10.

b. Show the placement of the decimal 0.829 on the number line.

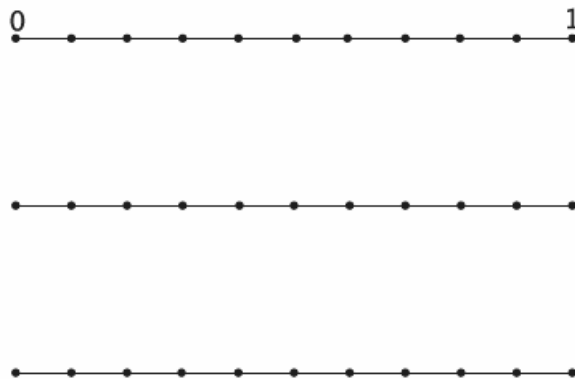

2.

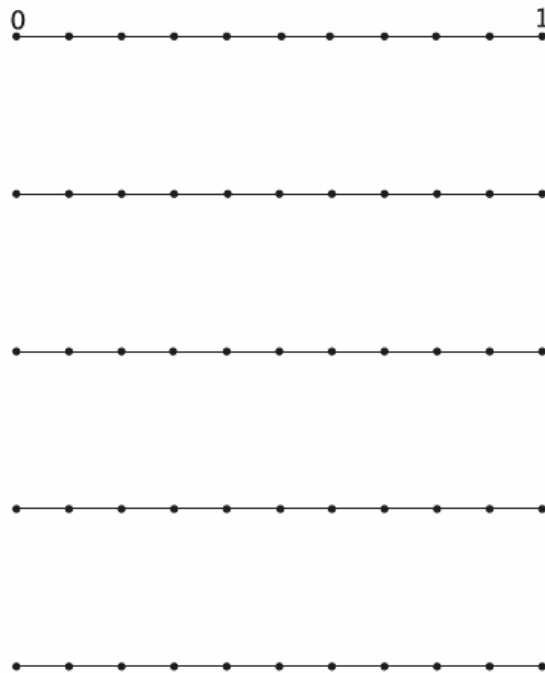
a. Write the expanded form of the decimal $0.55555\dots$ using powers of 10.b. Show the first few stages of placing the decimal $0.55555\dots$ on the number line.

3.

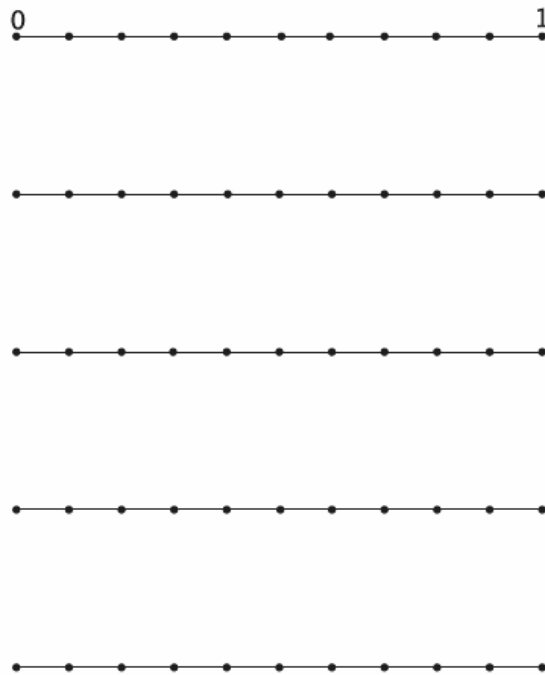
a. Write the expanded form of the decimal $0.\overline{573}$ using powers of 10.b. Show the first few stages of placing the decimal $0.\overline{573}$ on the number line.

Name _____

Date _____

Lesson 8: The Long Division Algorithm

Exit Ticket

1. Will the decimal expansion of $\frac{125}{8}$ be finite or infinite? Explain. If we were to write the decimal expansion of this rational number as an infinitely long decimal, which block of numbers repeat?

2. Write the decimal expansion of $\frac{13}{7}$ as an infinitely long repeating decimal.

Name _____

Date _____

Lesson 9: Decimal Expansions of Fractions, Part 1

Exit Ticket

Suppose $x = \frac{2}{3} = 0.6666\dots$ and $y = \frac{5}{9} = 0.5555\dots$

- a. Using 0.666 as an approximation for x and 0.555 as an approximation for y , find an approximate value for $x + y$.

- b. What is the true value of $x + y$ as an infinite decimal?

- c. Use approximations for x and y , each accurate to within an error of $\frac{1}{10^5}$, to estimate a value of the product $x \times y$.

Name _____

Date _____

Lesson 10: Converting Repeating Decimals to Fractions

Exit Ticket

1. Find the fraction equal to $0.\overline{534}$.

2. Find the fraction equal to $3.0\overline{15}$.

Name _____

Date _____

Lesson 11: The Decimal Expansion of Some Irrational Numbers

Exit Ticket

Determine the three-decimal digit approximation of the number $\sqrt{17}$.

Name _____

Date _____

Lesson 12: Decimal Expansions of Fractions, Part 2

Exit Ticket

Find the decimal expansion of $\frac{41}{6}$ without using long division.

Name _____

Date _____

Lesson 13: Comparing Irrational Numbers

Exit Ticket

Place each of the following numbers at its approximate location on the number line: $\sqrt{12}$, $\sqrt{16}$, $\frac{20}{6}$, $3.\overline{53}$, and $\sqrt[3]{27}$.

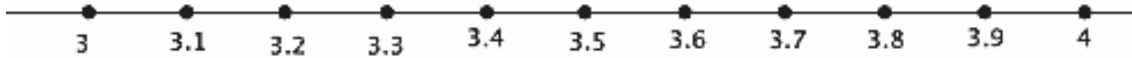

Name _____

Date _____

Lesson 14: Decimal Expansion of π

Exit Ticket

Describe how we found a decimal approximation for π .

Name _____

Date _____

Lesson 15: Pythagorean Theorem, Revisited

Exit Ticket

Explain a proof of the Pythagorean theorem in your own words. Use diagrams and concrete examples, as necessary, to support your explanation.

Name _____

Date _____

Lesson 17: Distance on the Coordinate Plane

Exit Ticket

Use the following diagram to answer the questions below.

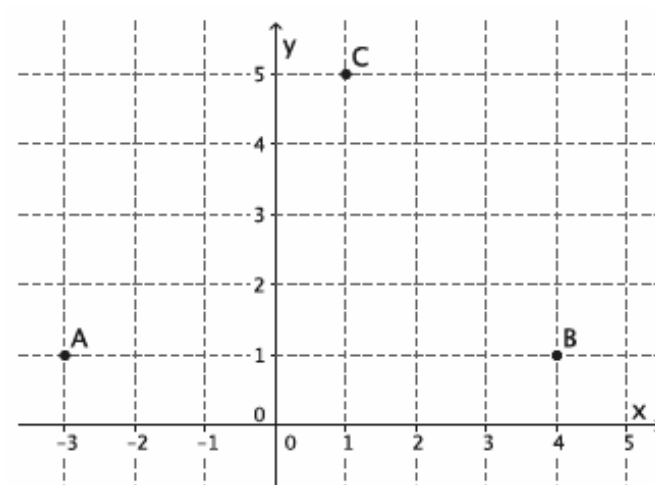

1. Determine $|AC|$. Leave your answer in square root form unless it is a perfect square.
2. Determine $|CB|$. Leave your answer in square root form unless it is a perfect square.
3. Is the triangle formed by the points A, B, C a right triangle? Explain why or why not.

Name _____

Date _____

Lesson 18: Applications of the Pythagorean Theorem

Exit Ticket

Use the diagram of the equilateral triangle shown below to answer the following questions. Show the work that leads to your answers.

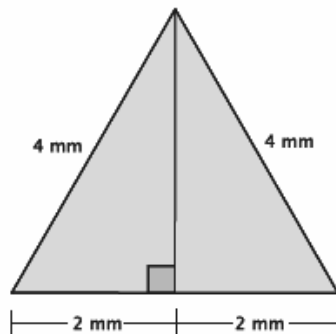

- What is the perimeter of the triangle?
- What is the height, h mm, of the equilateral triangle? Write an exact answer using a square root and an approximate answer rounded to the tenths place.

- c. Using the approximate height found in part (b), estimate the area of the equilateral triangle.

Name _____

Date _____

Lesson 19: Cones and Spheres

Exit Ticket

Which has the larger volume? Give an approximate answer rounded to the tenths place.

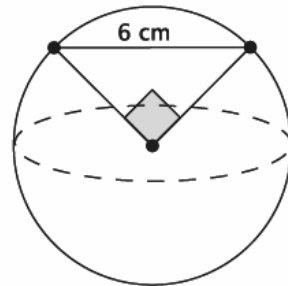
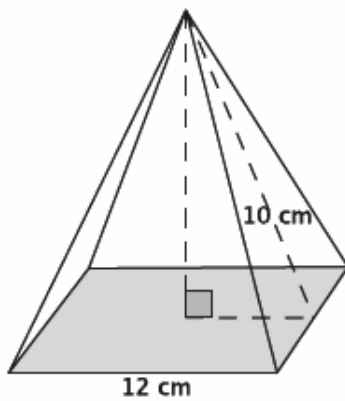

Name _____

Date _____

Lesson 20: Truncated Cones

Exit Ticket

Find the volume of the truncated cone.

- a. Write a proportion that will allow you to determine the height of the cone that has been removed. Explain what all parts of the proportion represent.

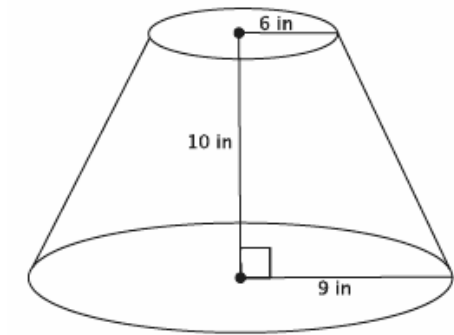

- b. Solve your proportion to determine the height of the cone that has been removed.

- c. Write an expression that can be used to determine the volume of the truncated cone. Explain what each part of the expression represents.

- d. Calculate the volume of the truncated cone.

Name _____

Date _____

Lesson 21: Volume of Composite Solids

Exit Ticket

Andrew bought a new pencil like the one shown below on the left. He used the pencil every day in his math class for a week, and now his pencil looks like the one shown below on the right. How much of the pencil, in terms of volume, did he use?

Note: Figures are not drawn to scale.

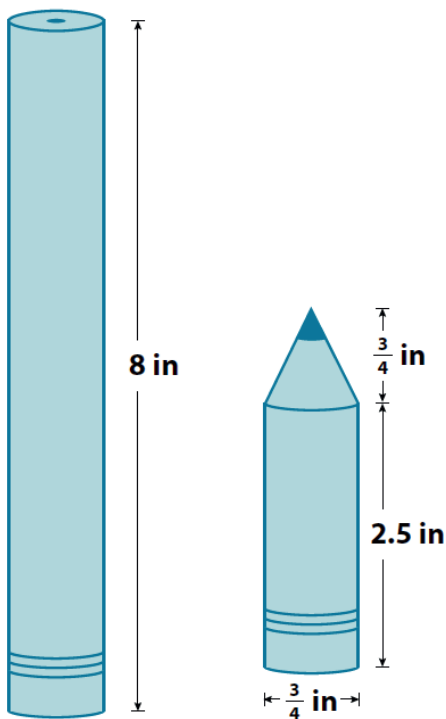

Name _____

Date _____

Lesson 22: Average Rate of Change

Exit Ticket

A container in the shape of a square base pyramid has a height of 5 ft. and a base length of 5 ft., as shown. Water flows into the container (in its inverted position) at a constant rate of 4 ft^3 per minute. Calculate how many minutes it would take to fill the cone at 1 ft. intervals. Organize your data in the table below.

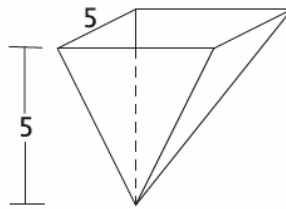

Water Level (in feet)	Area of Base (in ft^2)	Volume (in ft^3)	Time (in minutes)
1			
2			
3			
4			
5			

- How long will it take to fill up the container?
- Show that the water level is not rising at a constant rate. Explain.

Name _____

Date _____

Lesson 23: Nonlinear Motion

Exit Ticket

Suppose a book is 5.5 inches long and leaning on a shelf. The top of the book is sliding down the shelf at a rate of 0.5 in. per second. Complete the table below. Then, compute the average rate of change in the position of the bottom of the book over the intervals of time from 0 to 1 second and 10 to 11 seconds. How do you interpret these numbers?

Input (in seconds) t	Output (in inches) d $= \sqrt{30.25 - (5.5 - 0.5t)^2}$
0	
1	
2	
3	
4	
5	
6	
7	
8	
9	
10	
11	

Assessment Packet

Name _____

Date _____

1.

a. What is the decimal expansion of the number $\frac{35}{7}$? Is the number $\frac{35}{7}$ rational or irrational? Explain.

b. What is the decimal expansion of the number $\frac{4}{33}$? Is the number $\frac{4}{33}$ rational or irrational? Explain.

2.

a. Write $0.\overline{345}$ as a fraction.b. Write $2.\overline{840}$ as a fraction.c. Brandon stated that 0.66 and $\frac{2}{3}$ are equivalent. Do you agree? Explain why or why not.

d. Between which two positive integers does $\sqrt{33}$ lie?

e. For what integer x is \sqrt{x} closest to 5.25? Explain.

3. Identify each of the following numbers as rational or irrational. If the number is irrational, explain how you know.

a. $\sqrt{29}$

b. $5.\overline{39}$

c. $\frac{12}{4}$

d. $\sqrt{36}$

e. $\sqrt{5}$

f. $\sqrt[3]{27}$

g. $\pi = 3.141592\cdots$

h. Order the numbers in parts (a)–(g) from least to greatest, and place them on a number line.

4. Circle the greater number in each of the pairs (a)–(e) below.
- Which is greater, 8 or $\sqrt{60}$?
 - Which is greater, 4 or $\sqrt{26}$?
 - Which is greater, $\sqrt[3]{64}$ or $\sqrt{16}$?
 - Which is greater, $\sqrt[3]{125}$ or $\sqrt{30}$?
 - Which is greater, -7 or $-\sqrt{42}$?
 - Put the numbers 9, $\sqrt{52}$, and $\sqrt[3]{216}$ in order from least to greatest. Explain how you know which order to put them in.

5.

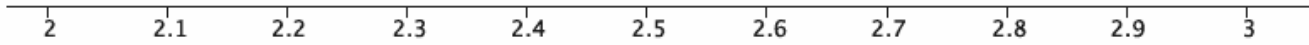

a. Between which two labeled points on the number line would $\sqrt{5}$ be located?

b. Explain how you know where to place $\sqrt{5}$ on the number line.

c. How could you improve the accuracy of your estimate?

6. Determine the positive solution for each of the following equations.

a. $121 = x^2$

b. $x^3 = 1000$

c. $17 + x^2 = 42$

d. $x^3 + 3x - 9 = x - 1 + 2x$

- e. The cube shown has a volume of 216 cm^3 .
- i. Write an equation that could be used to determine the length, l , of one side.

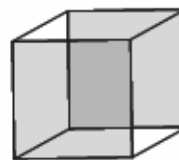

$$V = 216 \text{ cm}^3$$

- ii. Solve the equation, and explain how you solved it.

Name _____

Date _____

When using a calculator to complete the assessment, use the π key and the full display of the calculator for computations.

1.

a. Is a triangle with side lengths of 7 cm, 24 cm, and 25 cm a right triangle? Explain.

b. Is a triangle with side lengths of 4 mm, 11 mm, and 15 mm a right triangle? Explain.

c. The area of the right triangle shown below is 30 ft^2 . The segment XY has a length of 5 ft. Find the length of the hypotenuse.

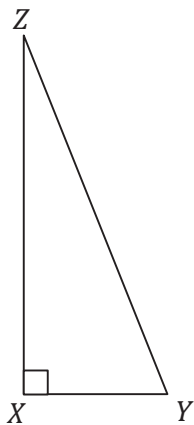

- d. Two paths from school to the store are shown below: One uses Riverside Drive, and another uses Cypress and Central Avenues. Which path is shorter? By about how much? Explain how you know.

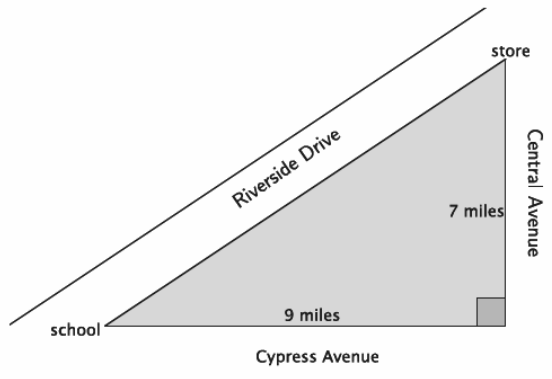

- e. What is the distance between points A and B ?

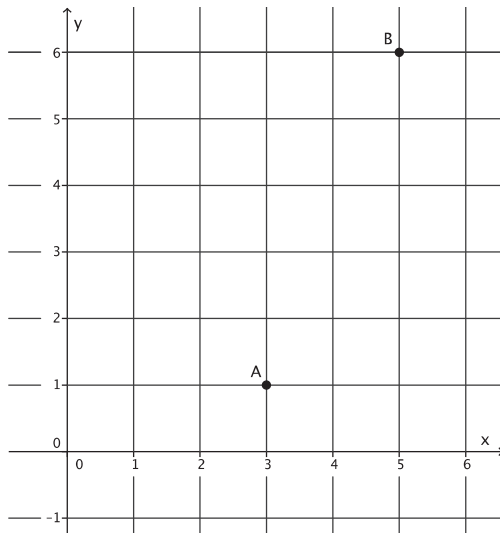

- f. Do the segments connecting the coordinates $(-1, 6)$, $(4, 2)$, and $(7, 6)$ form a right triangle? Show work that leads to your answer.

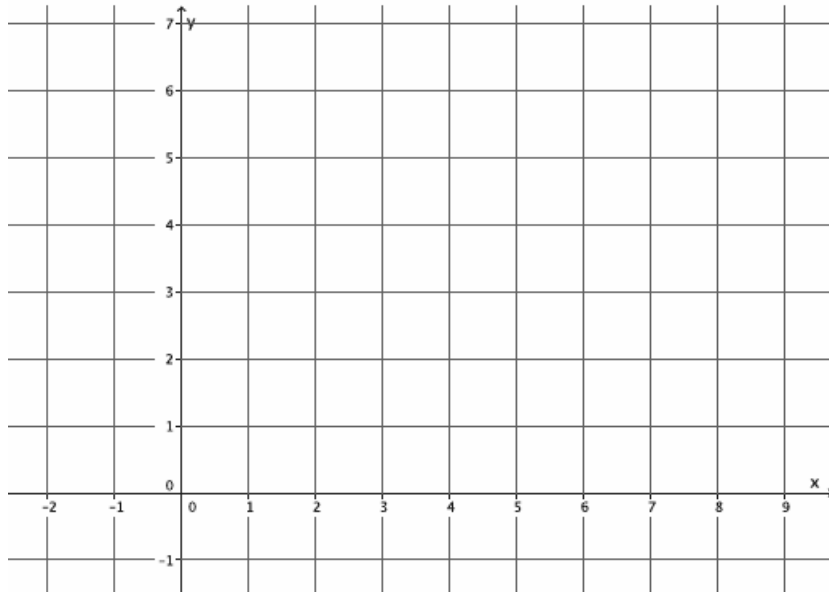

- g. Using an example, illustrate and explain the Pythagorean theorem.

- h. Using a different example than in part (g), illustrate and explain the converse of the Pythagorean theorem.
- i. Explain a proof of the Pythagorean theorem and its converse.

2. Dorothy wants to purchase a container that will hold the most sugar. Assuming each of the containers below can be completely filled with sugar, write a note recommending a container, including justification for your choice.

Note: The figures are not drawn to scale.

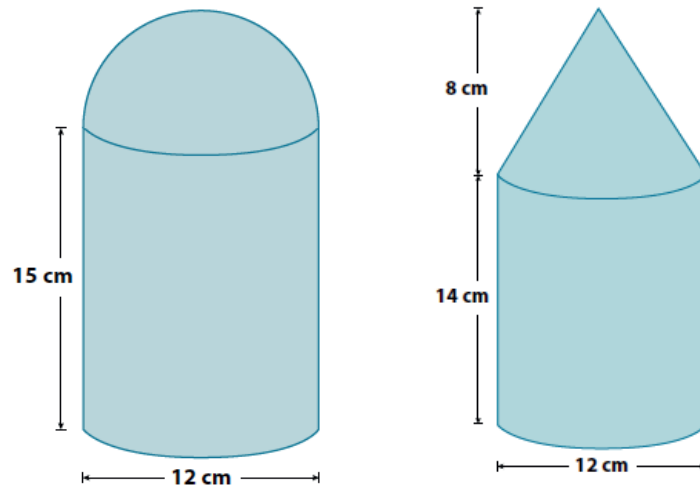

3.

- a. Determine the volume of the cone shown below. Give an answer in terms of π and an approximate answer rounded to the tenths place.

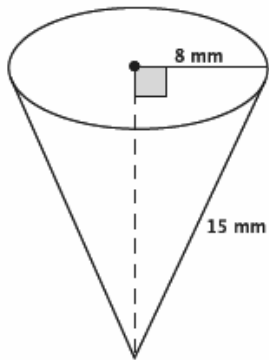

- b. The distance between the two points on the surface of the sphere shown below is 10 inches. Determine the volume of the sphere. Give an answer in terms of π and an approximate answer rounded to a whole number.

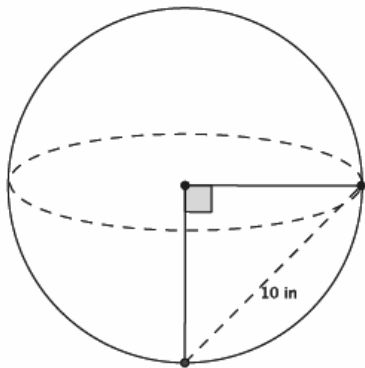

- c. A sphere has a volume of $457\frac{1}{3}\pi \text{ in}^3$. What is the radius of the sphere?